

Sturmey ***Archer***

Technical Information
and Parts List
Three Speed Hub
with Coaster Brake
Type AWC

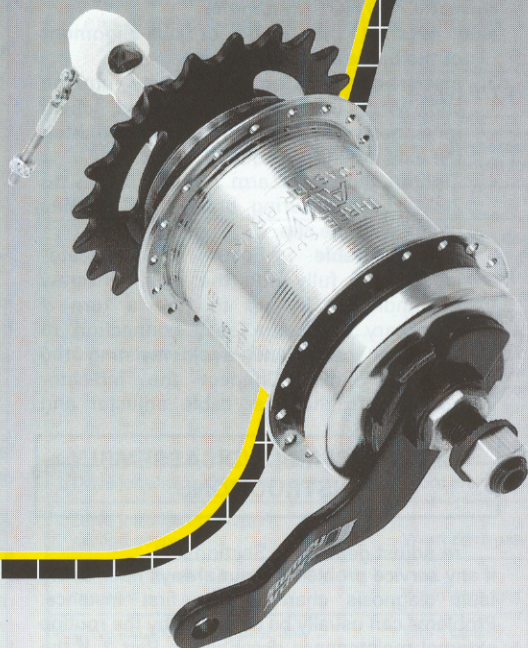

Part 1 GENERAL INFORMATION

Sturmey-Archer's AWC 3 Speed Coaster Brake Hub combines over 90 years experience of 3 speed gear hub design with state-of-the-art manufacturing technology. Correct attention to the small amount of routine adjustment and routine maintenance will ensure many years of trouble free service.

1.1 Gear Changing

Gear changing is simple and smooth with the proven Sturmey-Archer indexed control system. Continue pedalling, but ease pressure on the pedals, and select the gear required. If stationary, simply select gear required.

1.2 Gear Ratios

The AWC hub has three gears:

- 1st gear - Decrease of 25%
- 2nd gear - Direct Drive
- 3rd gear - Increase of 33%

The overall drive ratio can be altered by changing the size of the sprocket. Sturmey-Archer supply a range of sprockets from 14 to 22 teeth, suitable for 1/2" pitch x 1/8" chain.

1.3 Braking

The Sturmey-Archer coaster brake stops the bicycle safely, smoothly and quickly. To apply maximum braking effort, ensure the pedal cranks are horizontal. The remarkable brake efficiency results from the unique Sturmey-Archer design whereby the braking effort is enhanced by the mechanical advantage of the gears, regardless of which gear is selected.

Part 2 ROUTINE MAINTENANCE

2.1 Lubrication

No routine lubrication is required. However, during assembly/disassembly the hub greases should be replenished (see Section 4). Grease types meeting the following Sturmey-Archer technical Standards should be used:-

- For Bearings - SA103B
- For Brake Parts - SA103E
- For all other internal parts - SA103A

2.2 Gear Adjustment

1. Check that the fulcrum clip, if fitted, is secured tightly to the frame tube and that the indicator rod (4) is screwed correctly into the axle (See Section 3.1.5).
2. Select third gear at the control. Screw the cable adjuster (1) onto the indicator coupling (2).
3. Select the 2nd gear position on the gear

Gear Adjustment

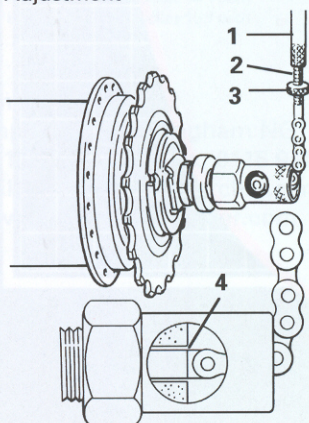

- control and turn the cable adjuster until the end of the indicator rod is exactly level with the end of the axle. This can be seen through the round window in the right hand axle nut (4).
4. Tighten the locknut (3) against the adjuster. If correct adjustment cannot be achieved, the fulcrum clip must be moved in the appropriate direction along the frame tube. Re-tighten the clip and adjust as described above.

2.3 Hub Bearing Adjustment

The right hand cone is preset at the Sturmey-Archer factory and should only be disturbed during a major service. The left-hand cone only is used for normal bearing adjustment.

1. Loosen left-hand cone locknut.
2. Adjust brake arm nut until very slight side play can be felt at the wheel rim, and none at the hub.
3. Holding the brake arm nut stationary tighten the cone locknut (Torque 7-10 Nm).

Part 3 WHEEL FITTING

The Sturmey-Archer AWC Hub can be fitted into rear chainstay widths between 115mm - 122mm using the appropriate spacers. **NB: This product is not designed for bicycles with vertical rear dropouts.** If the wheel is removed, these instructions should be followed during re-assembly:-

3.1

1. With the chain on the sprocket place the hub axle into the chainstay ends.
2. Fit washers and axle nuts. Ensure that the serrations on the anti-rotation lockwashers face into the frame with the lugs located into the chainstay slots.

NB: Ensure the correct size anti-rotation washer (items 33 and 47) (to match the chainstay slot width of 9.5mm or 7.9mm) is used and fitted correctly. DO NOT tighten the axle nuts at this stage or mis-alignment of the brake arm may occur.

3. Insert brake arm on hub loosely into the clip. With the wheel centralised, chain tensioned and aligned correctly, tighten the axle nuts to a torque of 25NM.
4. Tighten the brake arm clip nut firmly to 7NM max., ensuring brake arm remains in line with the clip.
5. **Control Cable** - Ensure the indicator is screwed fully into the axle. Unscrew the indicator by up to half a turn if necessary to ensure easy connection to the gear cable and avoid twisting the indicator links. Connect the indicator coupling to the gear cable adjuster and

Part 4 ASSEMBLY/DISASSEMBLY INSTRUCTIONS

re-adjust gears (see Section 2.2). If any service problems occur always refer to the fault diagnosis chart in the first instance. Problems can usually be corrected by the routine external maintenance described in Part 2. If the problem persists a close inspection of the working parts inside the hub will be necessary by a qualified cycle mechanic.

4.1 Disassembly

NB: Item numbers in the illustrations refer to exploded view overleaf.

1. Remove the indicator rod, axle nuts and spacing washers.
2. Use a screwdriver carefully to release the sprocket circlip from the driver, then remove the spacing washers (if any), sprocket and outer dustcap (note the order of these parts to facilitate reassembly).
3. (See Fig.1) Clamp right hand end of axle in a vice and unscrew the left hand cone locknut, spacing washer, and brake arm nut. Remove the brake arm, left hand cone and dust cap assembly, and brake shoe segments. Remove the brake actuator assembly by turning hub-shell clockwise. Remove hub from vice.
4. Loosen the right hand ball ring and dustcap assembly with a C-spanner or hammer and punch. Unscrew the ball ring to release the internal assembly from the hub shell.
NB: If a replacement gear internal assembly (Item 60 on exploded view) is to be fitted, no further disassembly is required.
5. See (Fig.2). Clamp the left hand end of axle in the vice and remove right hand cone locknut, spacers (if any), lockwasher, cone and spring with cap. Lift off ball ring and ball cage assembly, together with the driver assembly. Separate the driver assembly from ball ring by compressing pawls and extracting the driver assembly through ball ring.
6. (See Fig. 3). Lift off gear ring assembly,

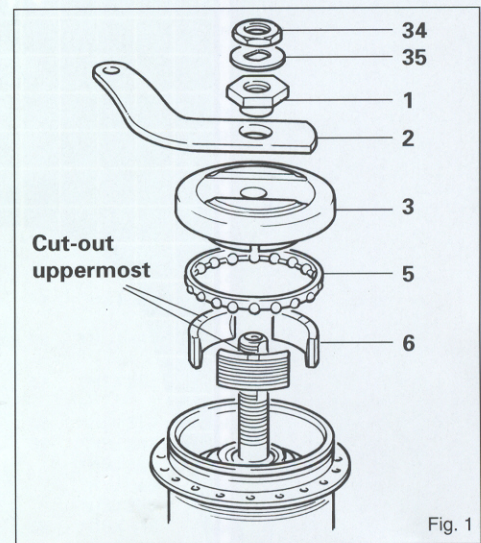

Fig. 1

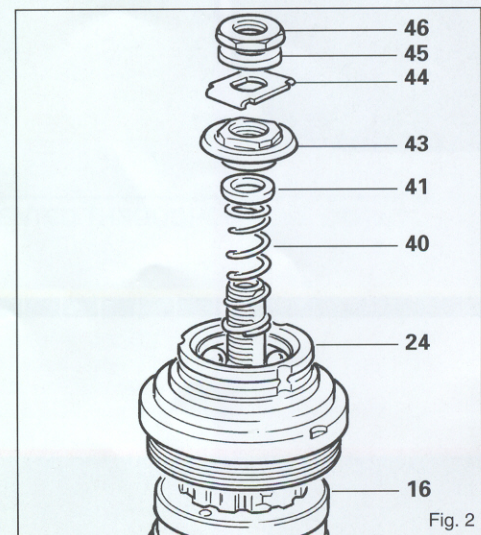

Fig. 2

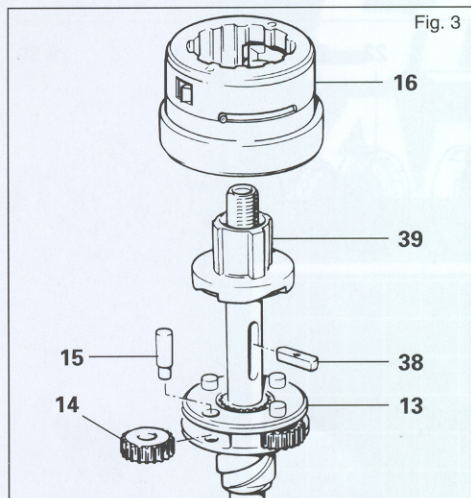

Fig. 3

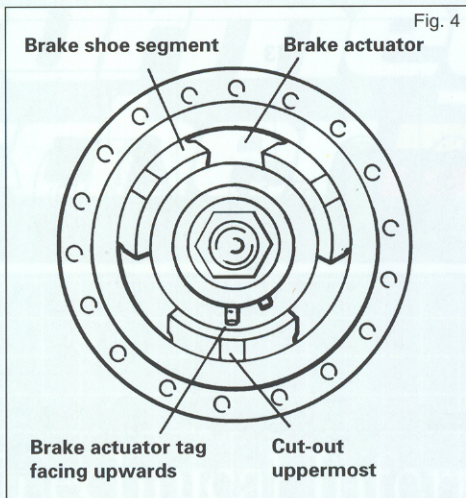

Fig. 4

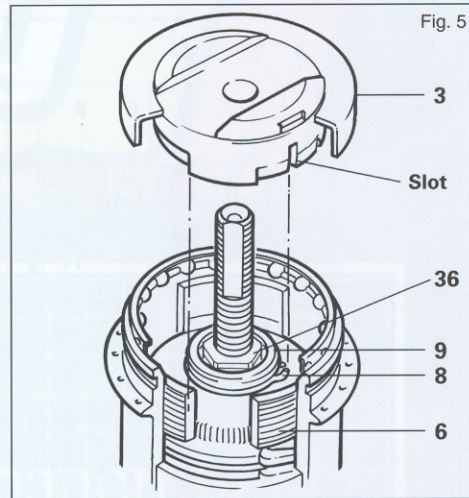

Fig. 5

clutch and axle key. Remove planet pinion pins and axle key. Remove axle from vice.

- Clamp right hand end of axle in vice and remove the two locknuts. Remove planet cage from axle and remove axle from vice.

4.2 Inspection and Repair of Internal Parts

Thoroughly clean all the internal parts and replace those worn or damaged. Specific items to be checked are:-

- Axle - straightness, condition of thread and slots.
- Condition of all pawls, springs, balls, ball tracks, pinions and gear ring teeth and drive slots.
- Check free movement of driver actuator and pawl action by inserting clutch and turn.

NB: It is recommended that this assembly is not dismantled but if necessary replace with a new assembly.

- Gear selector key** - Check threads for wear and free movement in axle slot.
- Clutch** - Check for wear of the pinion pin pockets and also squareness of drive corners.
- Brake actuator assembly** - Condition of pawls and pawl spring. Brake actuator spring should be able to turn clockwise readily, but have high resistance to turning anti-clockwise.
- Brake shoe segments** - Replace if worn.
- Left hand cone** - Condition of ball track.
- Brake Arm** - Replace if damaged.

4.3 Assembly

NB: All hub greases must be replenished during assembly using lubricants to the following Sturmey-Archer Technical Standards:

For Bearings - SA103B

For Brake Parts - SA103E

For all other internal parts - SA103A

If a complete replacement gear internal assembly (Item 60 on Exploded View) is to be fitted, assembly commences at Point 5 below:

- Locate planet cage over the axle with external screw thread facing away from axle slot. Screw first locknut down until finger tight. Slacken off 1/8 of a turn allowing free running of the planet cage with minimum axial movement. Hold the first locknut in place and screw down the second one to lock against it.
- (See Fig. 3). Clamp left hand end of axle in vice and fit the planet pinions and pins with the small diameter downwards. Fit the axle key (ensuring threaded hole is

vertical), clutch and gear ring assembly.

- (See Fig. 2). Fit the ball ring assembly then driver assembly compressing pawls to ensure driver ball track seats correctly on ball ring. Fit spring then cap.
- Screw down the right-hand cone finger tight. Unscrew the cone by half a turn. Fit the cone lockwasher. If the washer will not engage with the cone, unscrew the cone slightly. NB: Under no circumstances must the right hand cone be unscrewed more than 5/8" of a turn. Fit spacer washers (if required) then cone locknut and securely tighten to 7-10 Nm torque. Remove from vice.
- Insert hub assembly into the hub shell and securely tighten ball ring with C-spanner.
- Clamp right hand end of axle in vice and fit brake actuator assembly to left hand end of axle, turning clockwise to ensure the internal screw threads engage with planet cage. Fit the 3 brake shoe segments such that the cut-outs are uppermost (see Fig. 1), the tag of the brake actuator drag spring lines up with one of the cut-outs, and the three segments

are evenly spaced (see Fig. 4). If the brake actuator drag spring has been replaced, ensure that the tag faces upwards. Ensure that all brake parts are coated with grease to Sturmey-Archer Technical Standard SA103E.

- (See Fig. 1). Fit ball cage assembly, with balls facing down. Fit left hand cone, lining up the slot on the underside of the cone (See fig. 5) with the brake actuator drag spring tag. Slide over the axle to engage tag, checking the cone is correctly seated by rotating slightly ensuring that it engages with the brake shoe segments (see Fig. 5). Fit brake arm, spigotted brake arm locknut, washer and locknut. Adjust hub as described in Part 2. Remove hub from vice.

Note: For AWC hubs with segmented brake shoes: date prior to . If they require either LH cone, brake arm or brake arm lock nut replacing then a full LH service kit must be fitted.

- Assemble dustcap, sprocket and circlip in reverse order to disassembly.
- Assemble the wheel into the bicycle (see Section 3.1).

Part 5 FAULT DIAGNOSIS CHART

NB: Always check gear adjustment, condition of indicator, cable, control and tightness of fulcrum clip stop before referring to this chart.		
SYMPTOM	FAULT	REMEDY
1. Difficult to change gear	- Damaged indicator - Damaged cable - Damaged control - Loose fulcrum stop - Worn / damaged clutch spring	Replace Replace Replace Tighten Replace
2. Different gear engaged to gear selected	- Gear adjustment - Bearing adjustment - Wrong indicator - Worn clutch spring - Worn gear ring drag spring - Worn gear ring pawls	Adjust Adjust Replace Replace Replace gear ring assembly Replace gear ring assembly
3. Drive jolt/slips in first gear only	- Worn brake actuator pawls	Repace pawls
4. Drive jolt/slips in first and second gears	- Worn drive pawls in driver	Replace driver assembly
5. Drive jolt/slips in second and top gear	- Worn gear ring pawls	Replace gear ring assembly
6. Drive jolt/slips in top gear only	- Worn clutch - Worn planet pinion pins	Replace Replace
7. Harsh braking action	- Lack of lubrication	Grease all brake parts and surfaces
8. No brake	- Worn brake pawls in driver - Worn or incorrectly fitted brake actuator drag spring	Replace driver assembly Replace

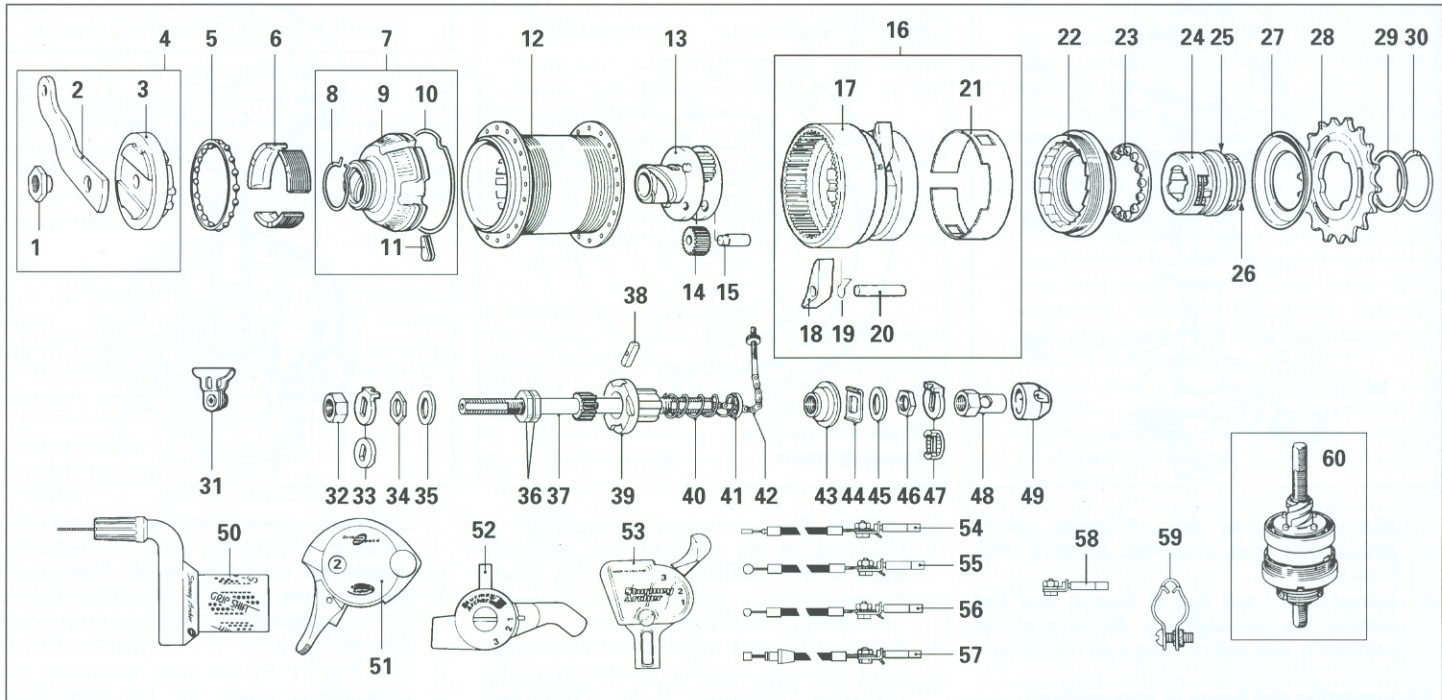

Item No.	Sales No.	Description	Item No.	Sales No.	Description	Item No.	Sales No.	Description
1	HMN 384	Spigotted Adjuster Nut	28	*HSL 716	Sprocket 16 Teeth	45	*HMW 484	Spacing Washer 6.4mm
2	HSB 483	Brake Arm		*HSL 717	Sprocket 17 Teeth	46	HMN 132	Cone Locknut
3	HSB 485	L.H. Cone & Dustcap Assembly		*HSL 718	Sprocket 18 Teeth	47	*HMW 155	Serrated Lockwasher - 7.9mm Slot
4	HSB 486	Brake Cone Service Kit complete		*HSL 719	Sprocket 19 Teeth		*HMW 494	Serrated Lockwasher - 9.5mm Slot
5	HSA 164	L.H. Ball Cage Assembly		*HSL 720	Sprocket 20 Teeth		*HMW 515	K48 Lockwasher
6	HSB 478	Brake Shoe Segments		*HSL 747	Sprocket 21 Teeth	48	HMN 129	R.H. Axle Nut
7	HSB 473	Brake Actuator Assembly (includes 2 off Item 11 and 1 off items 8,9, 10)		*HSL 722	Sprocket 22 Teeth	49	*HSL 711	Indicator Guard
8	HSB 407	Brake Actuator Drag Spring	29	HMW 127	Sprocket Spacing Washer 1.6 mm	50	*HSJ 880	Twistgrip Control c/w inner wire
9	HSB 476	Brake Actuator	30	HSL 721	Sprocket Circlip	51	*HSJ 865	Orion Control
10	HSAA 450	Brake Actuator Pawl Spring	31	*HSL 767	Brake Arm Clip Assembly with Integral Pad 15.5mm	52	*HSJ 823	Nimbus Control 22.2mm Clip
11	HSA 410	Brake Actuator Pawl				53	*HSJ 762	Trigger Control 22.2mm Clip
12	*HSA 400	Hub Shell & Ball Cup Assembly - 36H		*HCB 101	Brake Arm Clip Assembly - 15.9mm		*HSJ 765	Trigger Control 23.8mm Clip
	*HSA 465	Hub Shell & Ball Cup Assembly - 28H	32	HMN 128	Brake Arm Clip Assembly - 18.3mm	54	*HSJ 101	Trigger Cable with Anchorage 530mm x 1520mm Black
13	HSA 402	Planet Cage	33	*HMW 155	L.H. Axle Nut		*HSJ 102	Trigger Cable with Anchorage 1420mm x 1570mm Black
14	HSA 292	Planet Pinion		*HMW 494	Serrated Lockwasher - 7.9mm Slot			
15	HSA 401	Pinion Pin		*HMW 515	Serrated Lockwasher - 9.5mm Slot	55	*HSJ 884	Nimbus Cable with Anchorage 1420mm x 1570mm Black
16	HSA 554	Gear Ring Assembly (includes 1 off Items 17 & 21 and 2 off items 18, 19, 20)	34	HMN 132	K48 Lockwasher	56	*HSJ 882	Twistgrip Cable with Anchorage 1420mm x 1570mm Black
17	HSA 558	Gear Ring	35	HMW 150	Cone Locknut	57	*HSJ 883	Orion Cable with Anchorage 1420mm x 1570mm Black
18	HSA 119	Pawl for Gear Ring	36	HMW 382	Dog Ring Lockwasher	58	*HSL 759	Cable Anchorage
19	HSA 120	Pawl Spring	37	*HSA 538	Axle Locknut - 2 off	59	*HSJ 607	Chainstay Fulcrum Clip 12.7mm ø
20	HSA 415	Pawl Pin		*HSA 539	Axle 152mm		*HSJ 553	Chainstay Fulcrum Clip 15.9mm ø
21	HSA 542	Drag Spring	38	HSA 295	Axle 163mm		*HSJ 548	Chainstay Fulcrum Clip 17.9mm ø
22	HSA 437	Ball Ring	39	HSA 418	Axle Key		*HSJ 753	Chainstay Fulcrum Clip 19.1mm ø
23	HSA 438	Ball Cage Assembly	40	HSA 128	Clutch		*HSJ 753	Chainstay Fulcrum Clip 19.1mm ø
24	HSA 407	Driver Assembly (includes 1 off Items 25 and 26)	41	HSA 129	Clutch Spring		*HSX 116	Gear Internal Assembly Complete - 152mm Axle
25	HSA 284	Ball Cage Assembly R.H. - 6.4mm Ball	42	*HSA 126	Cap for Clutch Spring		*HSX 118	Gear Internal Assembly Complete - 163mm Axle
26	HSA 102	Outer Dustcap		*HSA 316	Gear Indicator (2 Mark) for 152mm Axle			
27	HSL 701	Sprocket Dustcap	43	HSA 101	Gear Indicator (4 Mark) for 163mm Axle			
28	*HSL 714	Sprocket 14 Teeth	44	HMW 147	R.H. Cone			
	*HSL 715	Sprocket 15 Teeth	45	*HMW 146	Cone Lockwasher			
				*HMW 129	Spacing Washer 1.6mm			
				*HMW 483	Spacing Washer 3.2mm			
					Spacing Washer 4.8mm			

* Optional Fitment

Sturmey-Archer Ltd.,
Triumph Road, Nottingham NG7 2GL, ENGLAND, U.K.
Tel: 0115 942 0800 Fax: 0115 942 0801
E-mail: info@sturmey-archer.com
URL: www.sturmey-archer.com

Persons Majestic MFG.,
21 Hamilton Street, MONROEVILLE, OHIO 44847 U.S.A.
Tel: (419) 465-2504 Fax: (419) 465-4070

REPRESENTED THROUGHOUT THE WORLD

LTE 117/6