

3237386

0.1 B

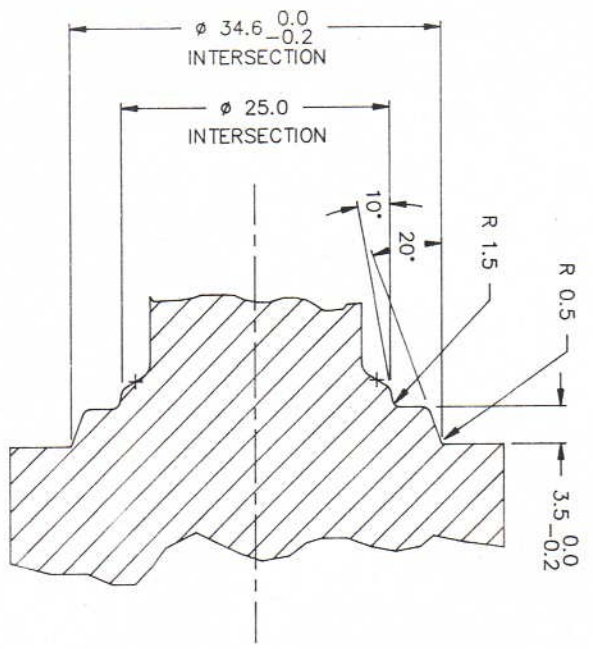
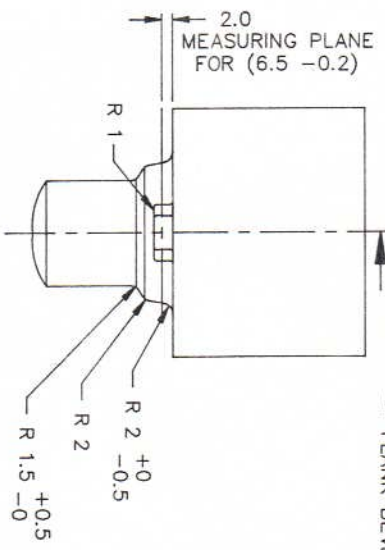
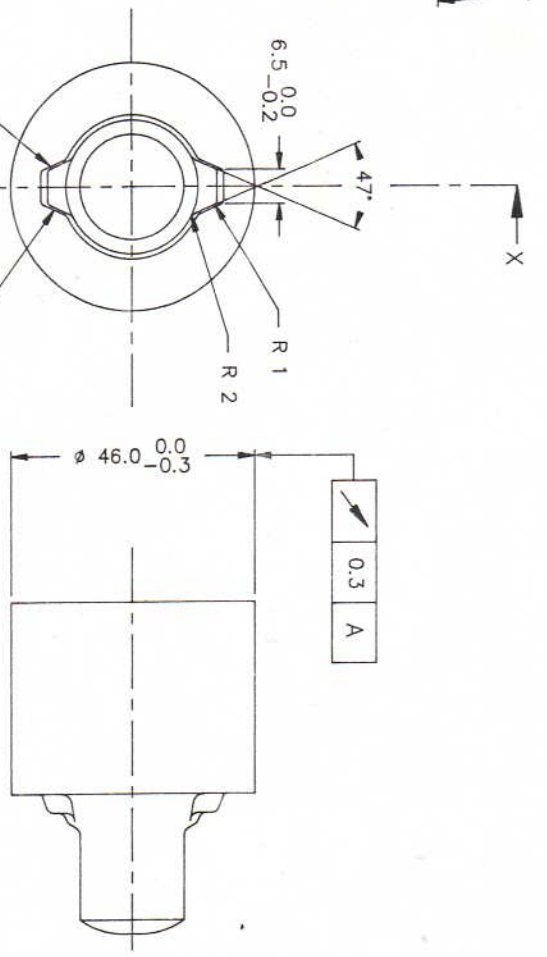
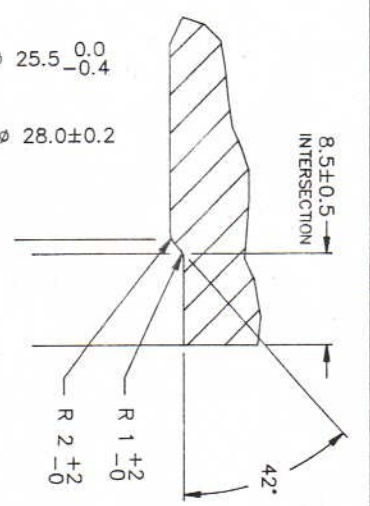
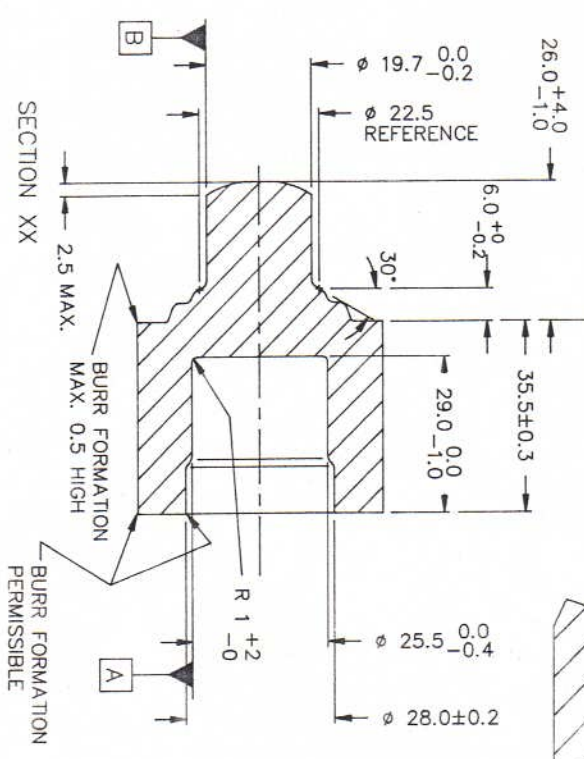

ENLARGED VIEW OF SECTION XX
SCALE 2 : 1

STURMEY-ARCHER LTD., NOTTINGHAM		A3 ©	
TOLERANCE U.O.S. TO BE AS FOLLOWS: - IMPERIAL: - DEC +/- .005 FRAC +/- .010 METRIC: - 0.XX +/- .1mm 0.X +/- .4mm ANGULAR: - +/- 2 DEGREES			
MATERIAL C 15			
HEAT TREATMENT			
CASE DEPTH	CASE HARDNESS	CORE HARDNESS	FINISH
AT POSITION	DO NOT SCALE DRAWING	SCALE 1 : 1	DRAWN SR
TITLE PLANET CAGE		DATE 18-9-90	DRG. No. 3237386
AMENDMENTS	ISSUED	00010 09/09/90	

3237388

Rz 25

TEETH IN THIS AREA TO EXACT DIMENSIONS

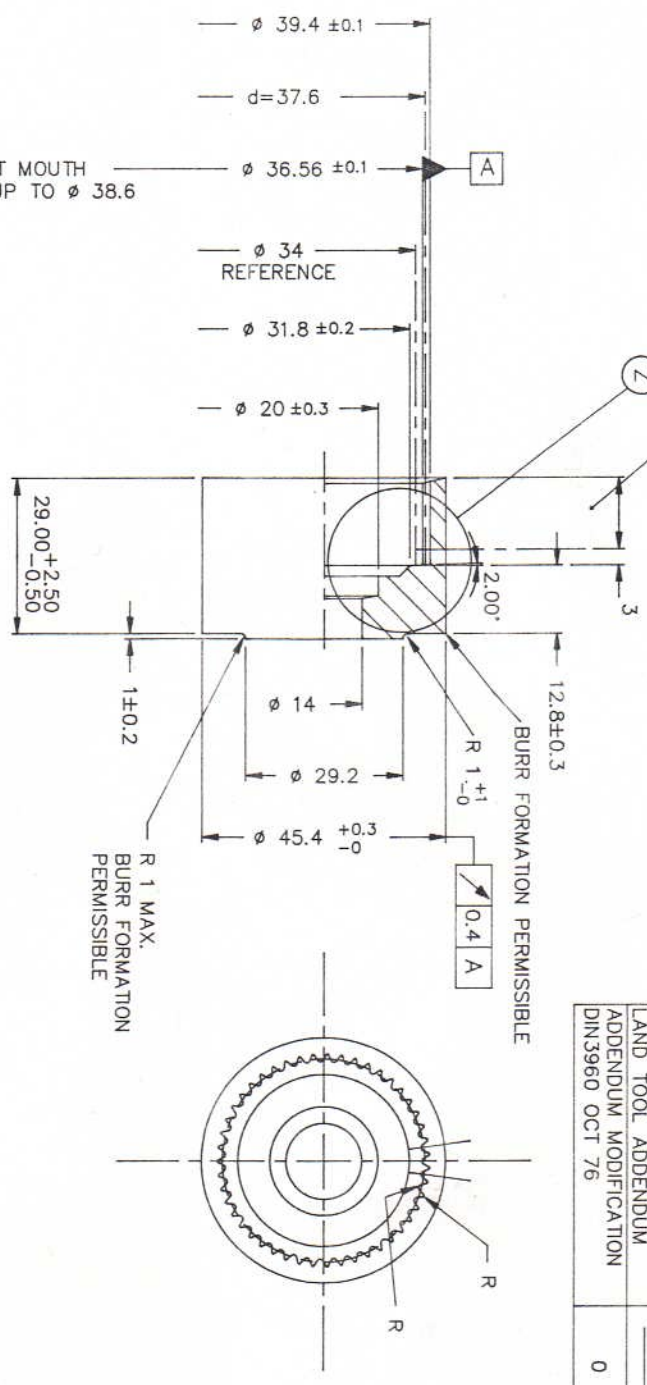

PITCH MODULE		mm	0.8
NUMBER OF TEETH	z	47	
PITCH CIRCLE DIAMETER	d	37.6	
BASIC PROFILE DIN		867	
PRESSURE ANGLE		27.50°	
BASE DIAMETER	db	33.352	
HELIX ANGLE		0°	
TOOTH ALIGNMENT	h _{oo}		
TOOL ADDENDUM		1.125*mm	
LAND TOOL ADDENDUM			
ADDENDUM MODIFICATION			
DIN3960 OCT 76		0	

QUALITY TOLERANCE ZONE		12e S
BASE TANGENT LENGTH W8		18.2 +0.2 -0
DIAMETER OVER 2 ROLLERS		35.5 +0.2 -0
ROLLER		φ 1.5
TOOTH COMPOSITE ERROR DOUBLE FLANK	f ₁	0.160
TOOTH TO TOOTH COMPOSITE ERROR DOUBLE FLANK	f ₂	0.056
TOTAL PITCH LINE ERROR FB	f _f	0.110
PROFILE MEASURING RANGE		0.090
MATING GEAR NUMBER		
CENTRE DISTANCE		12.8 ± 0.05

IN RELATION TO OUTSIDE DIAMETER OF FINISHED PART

DIMENSION AT MOUTH ALLOWABLE UP TO φ 38.6

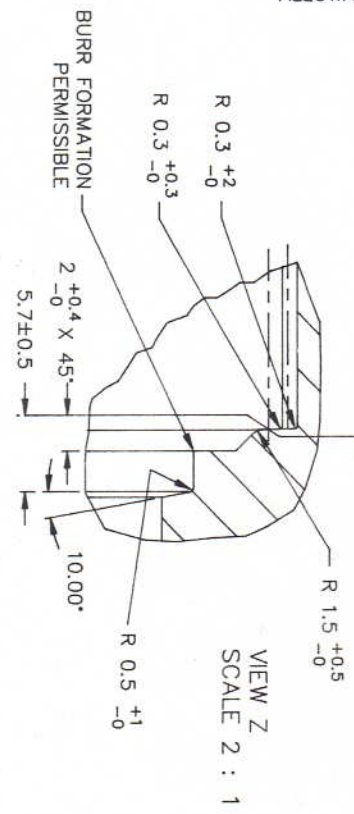

AMENDMENTS		HEAT TREATMENT		FINISH	
ISSUED		CASE DEPTH	CASE HARDNESS	DO NOT SCALE DRAWING	SCALE
00010	09/09/90				1 : 1
TITLE		CORE HARDNESS		DRAWN	
GEAR RING		AT POSITION		DATE	
		▽		19-9-90	
DRG. No.				SR	
3237388					

STURMEY-ARCHER LTD., NOTTINGHAM

A3 ©

TOLERANCE U.O.S. TO BE AS FOLLOWS:-
 IMPERIAL:- DEC +/- .005 FRACTIONAL +/- .010
 METRIC:- 0.XX +/- .1mm 0.X +/- .4mm
 ANGULAR:- +/- 2 DEGREES
 MATERIAL C 15
 ALL DIMENSIONS (U.O.S.) IN - MILLIMETRES
 AND ARE FINAL SIZES INCLUDING SURFACE
 FINISH EXCEPT ON STOCK THICKNESS U.O.S.
 FOR EXPLANATION OF DIMENSIONS, NOTES
 AND SYMBOLS ETC. SEE B.S. 308

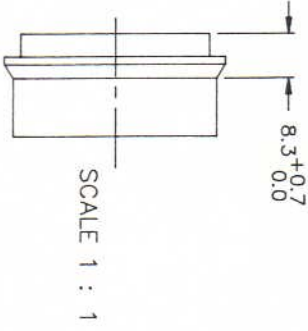
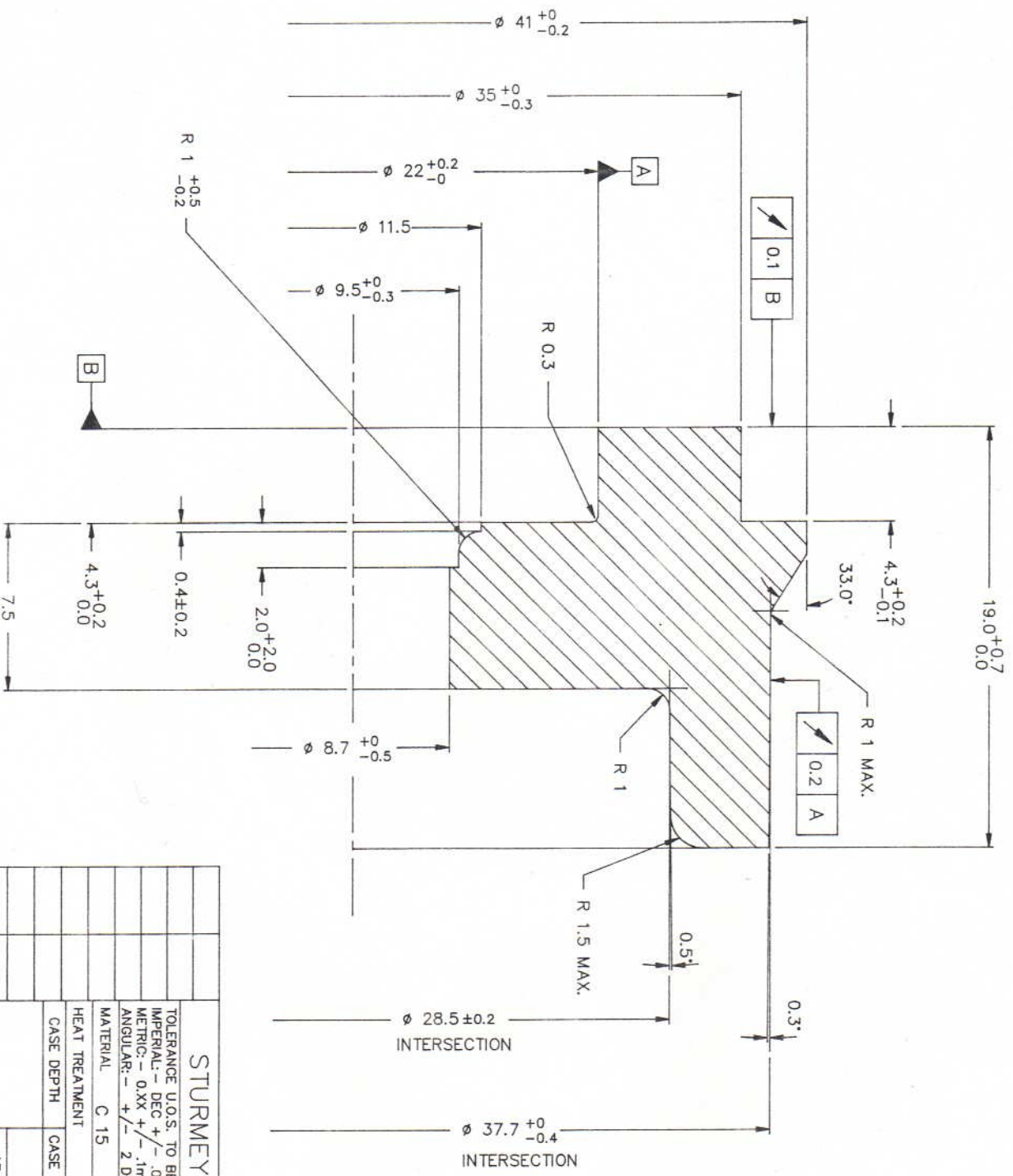

TOLERANCE U.O.S. TO BE AS FOLLOWS:- IMPERIAL: DEC + / - .005 FRAC + / - .010 METRIC: 0.XX + / - .1mm 0.X + / - .4mm ANGULAR: + / - 2 DEGREES		ALL DIMENSIONS (U.O.S.) IN - MILLIMETRES AND ARE FINAL SIZES INCLUDING SURFACE FINISH EXCEPT ON STOCK THICKNESS U.O.S. FOR EXPLANATION OF DIMENSIONS, NOTES AND SYMBOLS ETC. SEE B.S. 308	
MATERIAL C 15		HEAT TREATMENT	
CASE DEPTH	CASE HARDNESS	CORE HARDNESS	FINISH
			DO NOT SCALE
AT POSITION			DRAWING
TITLE		SCALE	DATE
LEFT HAND CONE		5 : 1	18-9-90
AMENDMENTS		DRG. No.	
ISSUED		3237387	
D0010 08/09/90			

STURMEY-ARCHER LTD., NOTTINGHAM